

Ultraviolet Telescope (UVT)

Brian Fleming, Kevin France, Dmitry Vorobiev, Tom Patton, (CU-LASP) and the STAR-X team

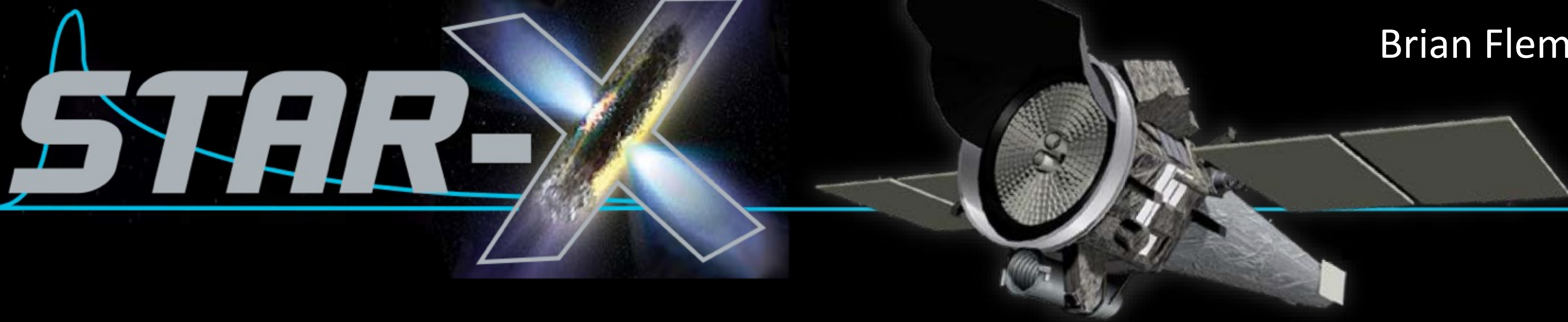

Instrument Overview

- Survey and Time-domain Astrophysical Research eXplorer
- A compact and efficient ultraviolet telescope complementing the powerful X-ray imager (XRT)
- 33 cm Ritchey-Chretien telescope design
- Five band imager covering primarily 160 – 400 nm
- 0.9 degree field-of-view with < 5" imaging
- Photon-counting detector capability
- Low-risk, high-heritage design

Observatory Diagram

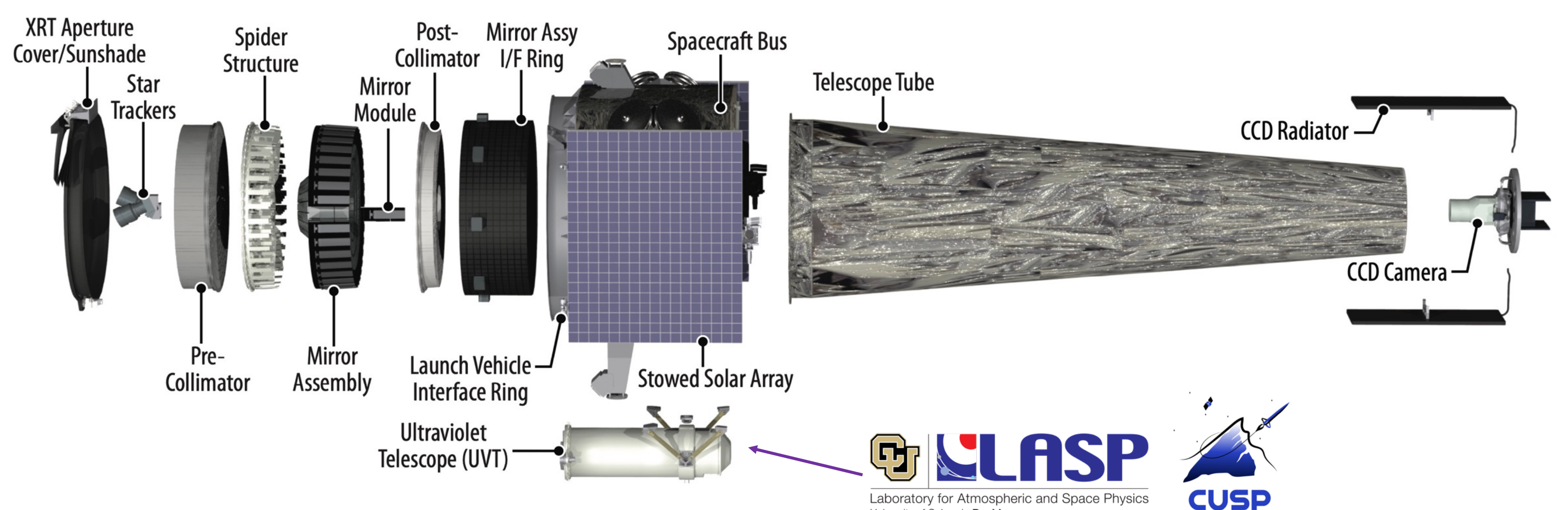

Design Details

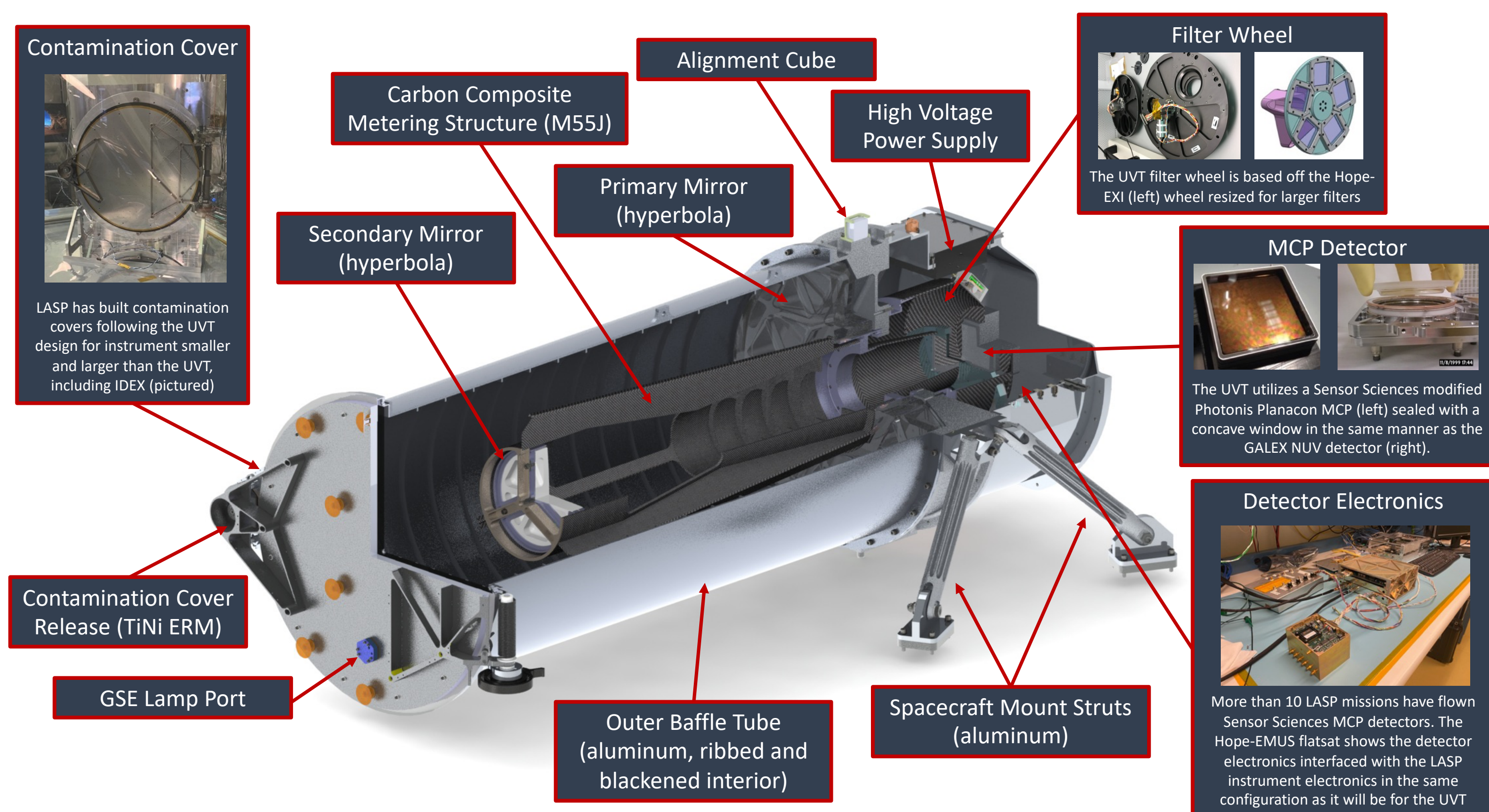

Performance Projections

- The UVT employs a compact and efficient design to meet all the STAR-X science requirements
- The UVT exceeds the FOV of *Swift*-UVOT and XMM-OM, and has more filters and better resolution than GALEX

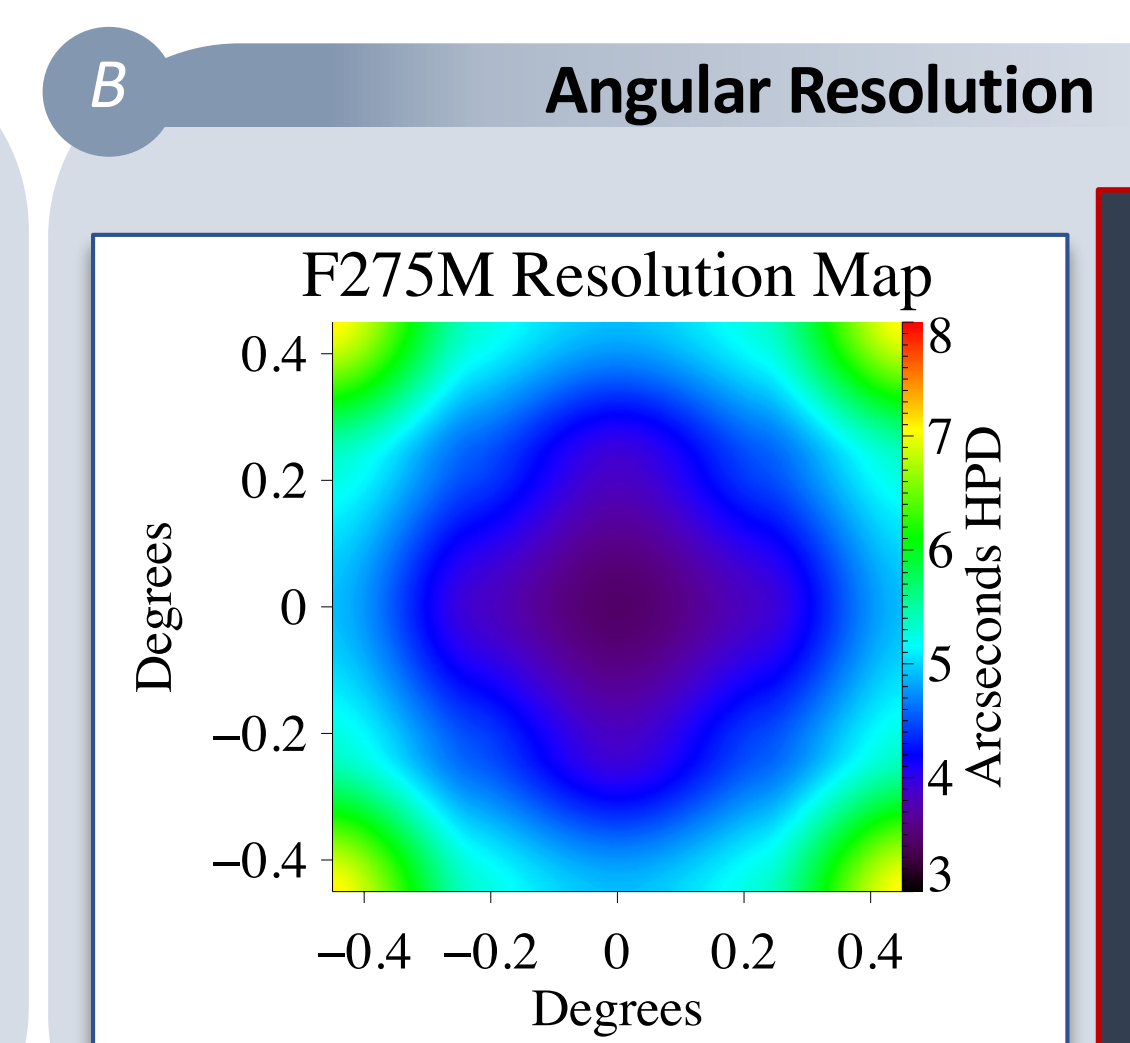
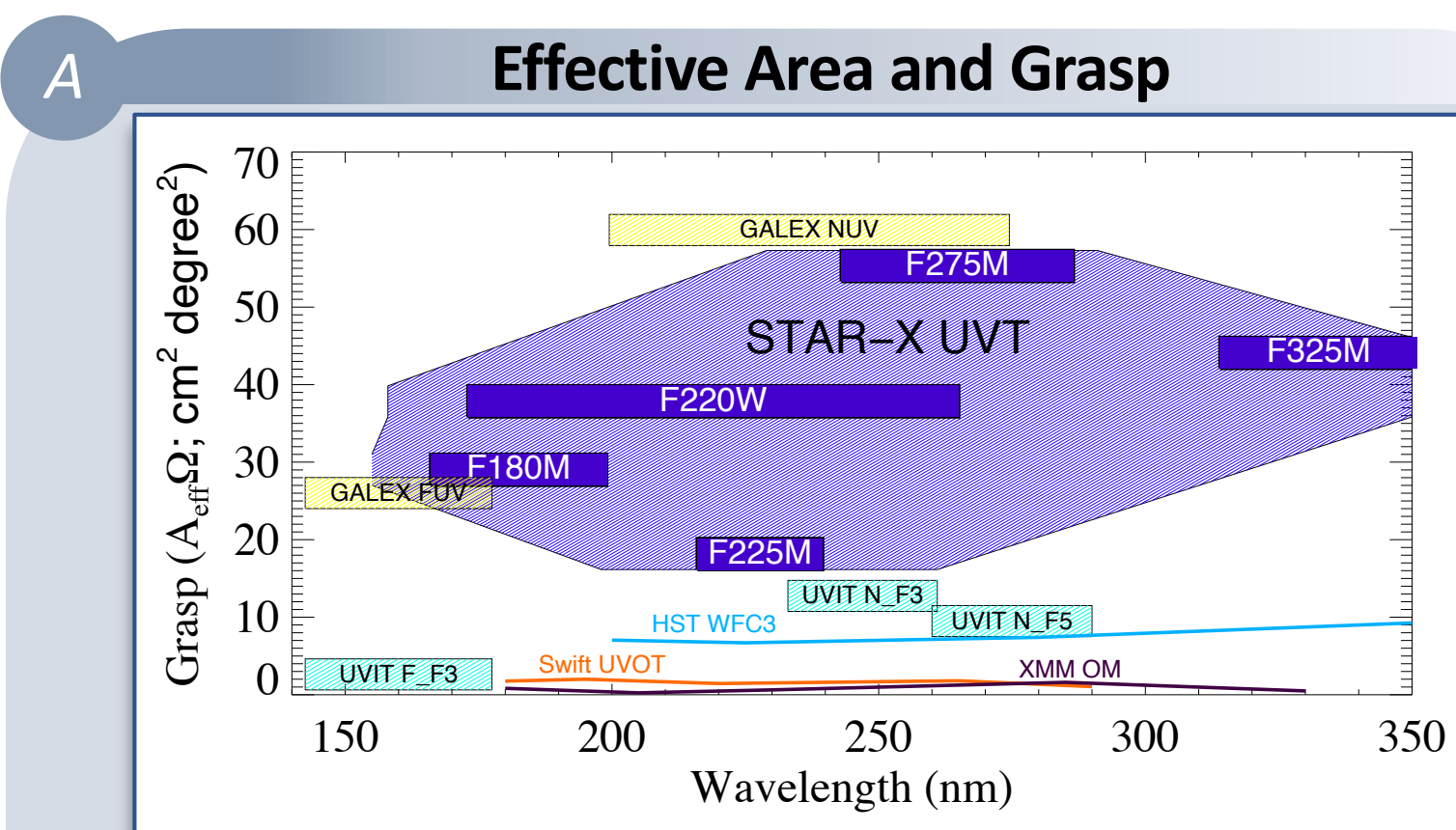

The Star-X UVT delivers better than 5 arcseconds HPD resolution for > 50% of the field-of-view, including instrument and pointing errors. This improves on GALEX NUV in the center of the UVT field-of-view

The Star-X UVT provides support for the XRT with a larger FOV than *Swift* UVOT and XMM-OM, and higher angular and bandpass resolution than GALEX.

UVT Filters and Bandpass

- F180, F225, F325, and F220W all Teledyne Acton Optics. F275 Asahi Spectra with heritage from PETREL
- Filter selection driven by throughput (F180 and F275) and excellent out-of-band performance (F225)

Filter	Bandpass (FWHM)	Notes
F180	160 - 230 nm	Far-UV coverage beyond UVOT
F225	200 - 260 nm	Excellent out-of-band suppression
F275	227 - 292 nm	Sharp edges and high throughput
F325	260 - 395 nm	Near-UV/Visible transition
F220W	160 - 540 nm	Wide-band coverage

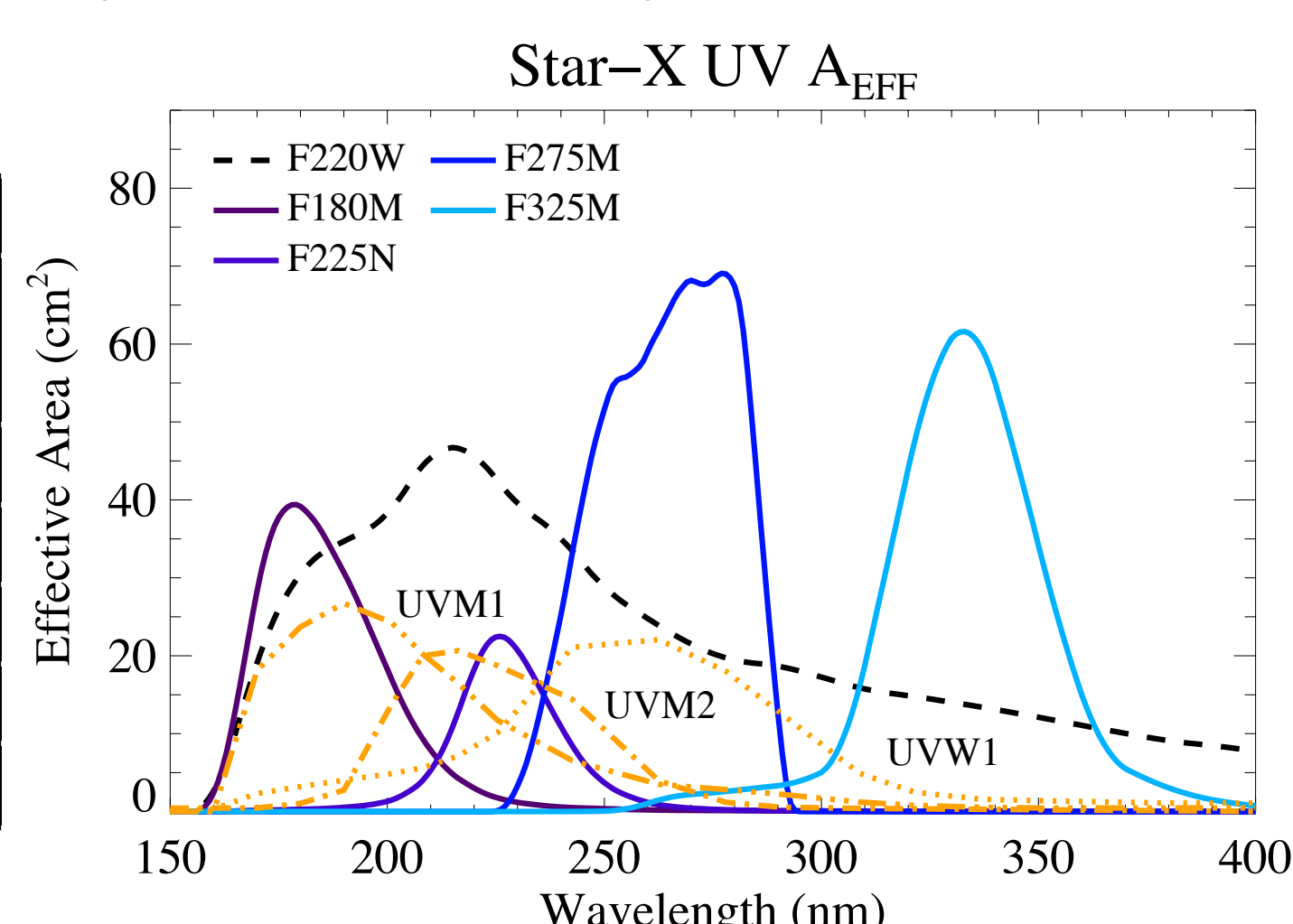

Star-X UVT Optical Block Diagram

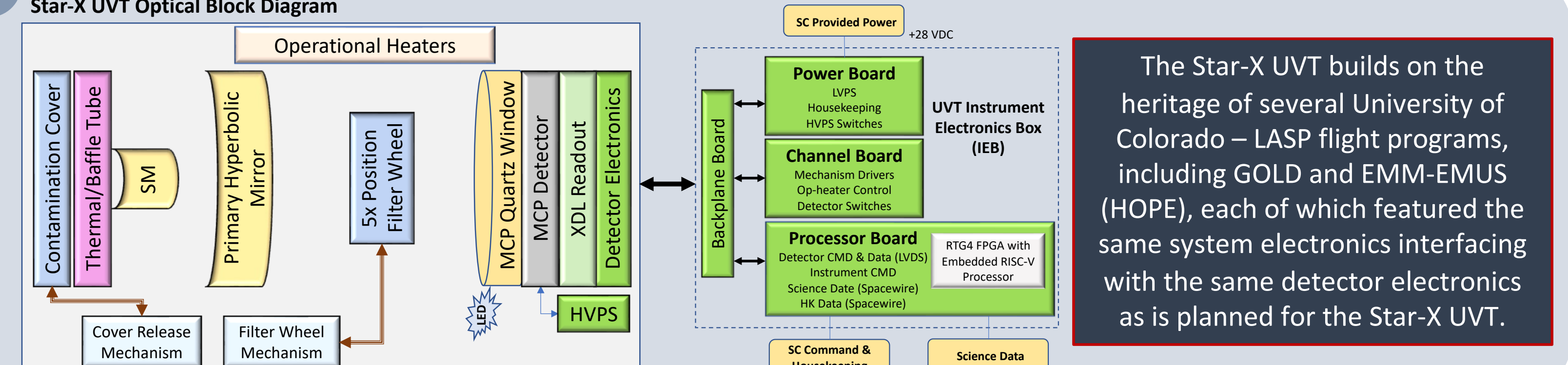

The Star-X UVT builds on the heritage of several University of Colorado – LASP flight programs, including GOLD and EMM-EMUS (HOPE), each of which featured the same system electronics interfacing with the same detector electronics as is planned for the Star-X UVT.

UVT Microchannel Plate Detector

- Photonis Planacon MCP
- Modified with Sensor Sciences cross-delay line (XDL) anode
- Sealed with a $R_c=200$ mm concave UV fused silica window
- Activated with High-QE UV cathode
- Sensor Sciences planetary electronics package (JUNO-UVS)
- Detector package has high high count rate tolerances – can observe > 10x brighter sources than GALEX
- Sealed system works at atmospheric pressures and room temperature with low background

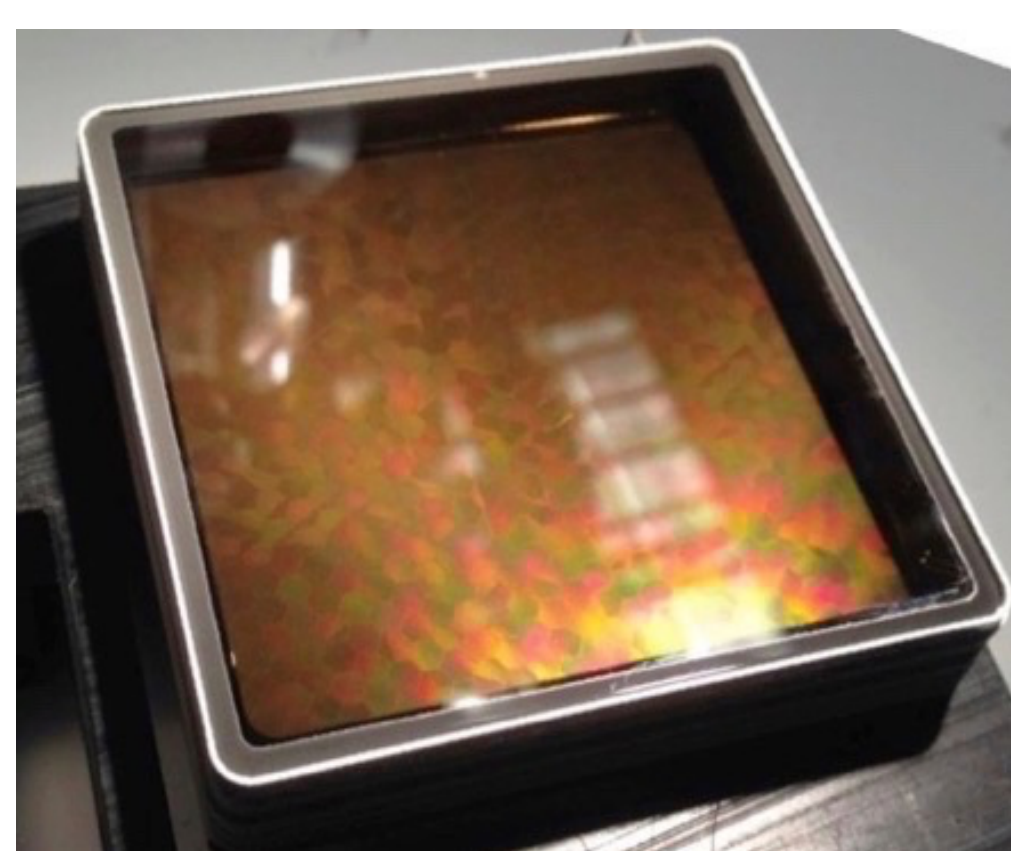

Science Output

- The UVT produces calibrated science frames of all survey fields on 300 – 500 second exposure time scales
- Time sequences of survey fields
- SEO/GO Option: Time tagging of photon data is available for short (~ 1 second) time series of variable objects
- The UVT will observe the Magellanic Clouds and Galactic plane, filling in regions missed by GALEX

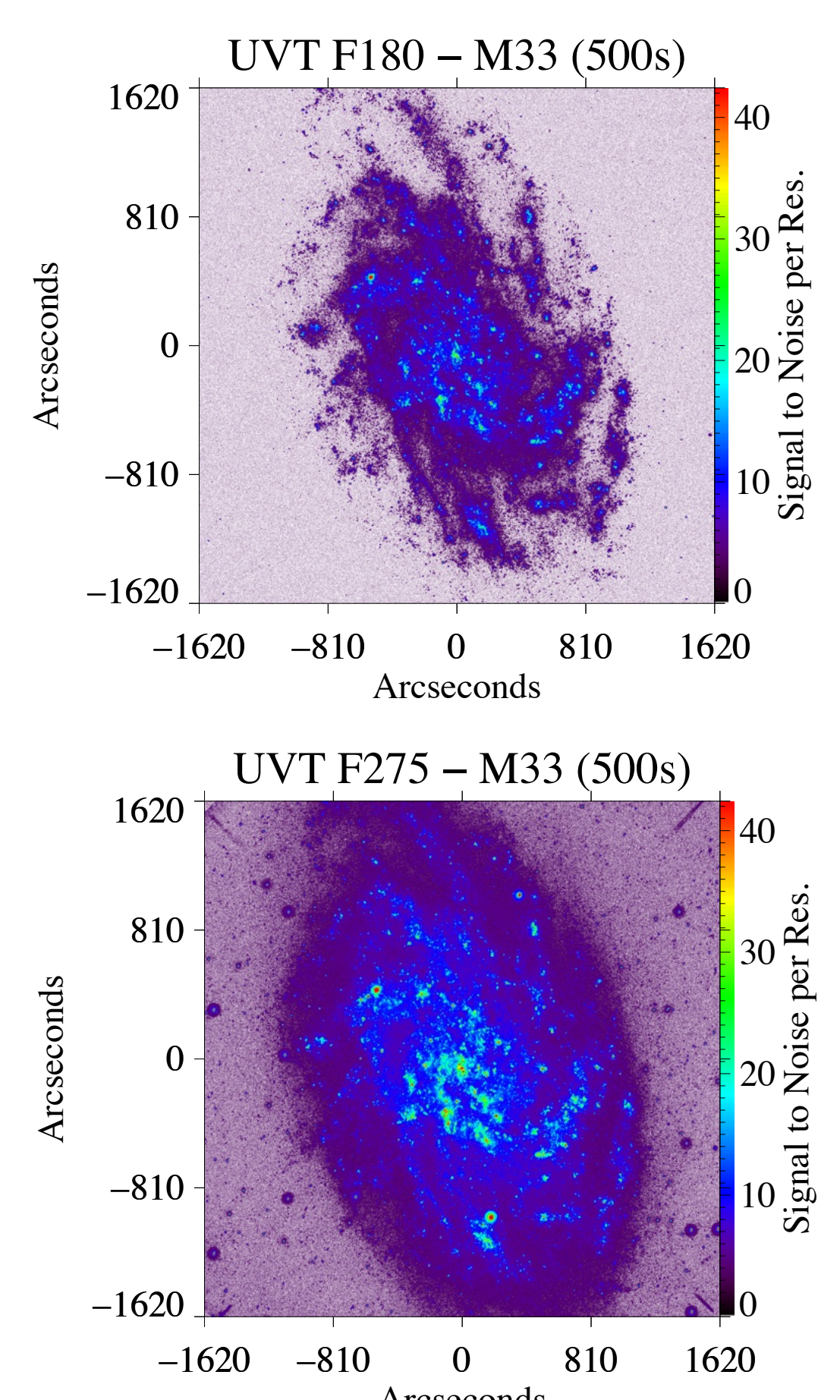

For more information

- STAR-X Special Session, Tuesday, 5 PM – 6:30 PM, Queen's Ballroom
- <http://star-x.xraydeep.org>

